



Extorr Inc.
307 Columbia Road
New Kensington, PA 15068
724-337-3000
Fax 724-337-8322

Application Note Number 21: What is the Difference Between a Helium Leak Detector and an RGA?

Abstract: It is often said that a Residual Gas Analyzer (RGA) may be used as a detector for leaks in a vacuum system. This note answers the question of what is the difference between “a detector for leaks in a vacuum system” and a helium leak detector.

A typical residual gas analyzer requires a pressure of 10^{-4} torr (one ten millionths of an atmosphere) or lower to operate. At these pressures and below, The RGA will ionize and detect the current of any molecule which is free to travel through the source (ionizer) of the RGA. One of the functions of an RGA is to determine if there are leaks into a high vacuum system.

To be of use, the typical RGA must be located in a vacuum system which is already at pressures below 10^{-4} torr. The RGA may then be used to determine if the air peaks at mass 28 and 32 are in the system. These peaks must be in a ratio of 4 to 1 and if the peaks are real, they will remain at a constant intensity. Also a true air leak will have mass 40 at about 1 % of the mass 28 peak. The location of the leak or leaks is then traced by spraying helium on the outside of the vacuum vessel and observing the increase and decrease of the mass 4 peak as the helium spray passes over the origin of the leak. Since the RGA is a mass spectrometer, the leak hunter is not just confined to using one leak detect gas. Although helium is probably most sensitive, argon or some volatile liquid could be used.

The Extorr probe, with its built-in Pirani and ion gauges can do all the leak detection of the ordinary RGA but can also give leak information at pressures many orders of magnitude above where the quadrupole will operate. The Pirani gauge will start operating right from atmospheric pressure. If you can not hear the whistling of the leak, spraying a little fluorocarbon, such as comes from a can of keyboard cleaner, will make the Pirani respond rapidly to locate the leak. When the pressure gets to below 10^{-2} torr the ion gauge can perform the same function.

As well as the Extorr RGA works for certain applications the vacuum leak detector will work better for other applications. Both RGA and the leak detector can use helium as the tracer gas but the helium leak detector must use helium. The helium leak detector has a self contained vacuum system and will not require the vessel to be checked to have a vacuum pump on it. In fact such a pump will interfere with the leak detection. The vessel under test is pumped out through the roughing pump of the helium leak detector. This roughing pump also backs the turbomolecular pump which evacuates the helium mass spectrometer. After the vessel under test is pumped to a rough vacuum, helium is sprayed on the outside of the vessel. If helium makes it through a leak into the vacuum, the helium will move through the roughing lines and diffuse “backward” through the spinning turbo blades to be registered by the mass spectrometer tuned to mass 4. Usually an audio as well as a video display will indicate the increasing helium peak intensity. The location of a leak may be

traced in much the same way as the RGA was used by passing over a leak with a helium spray. By surrounding the entire vessel, the helium leak detector may also be calibrated to give a helium leak rate in terms of standard atmospheric cubic centimeters per second.

The difference between the RGA and the helium leak detector are summarized in the figure below.

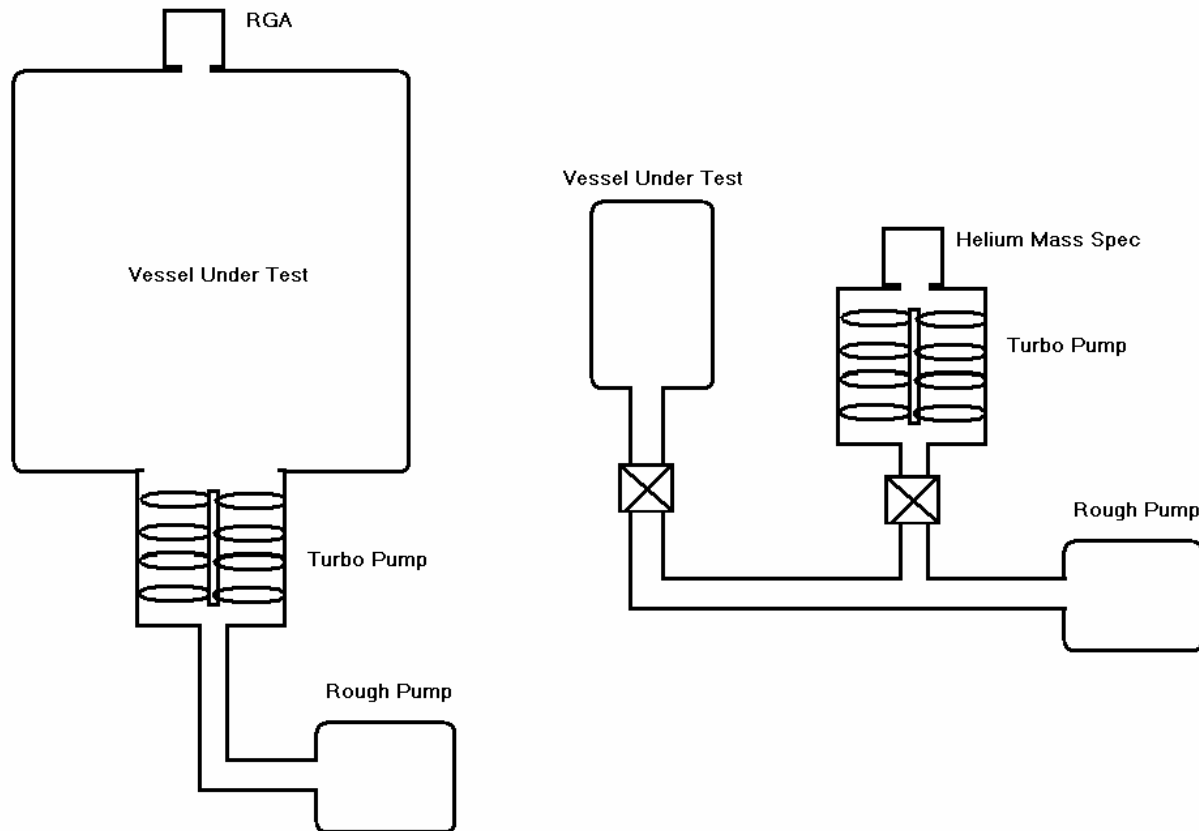

Both devices have their place and their applications rarely overlap. The RGA gives results in partial pressure (torr) and the helium leak detector gives results in leak rate (atm-cc/s).

If a vacuum system has a helium leak rate of 10^{-8} atm-cc/s, what is the measured partial pressure of helium? The answer to this depends on the geometry and pumping rate of the vacuum system. For a simple geometry as shown above, assuming a 100 liter/second turbomolecular pump, and using mass flow in equals mass flow out, we get 100 l/s times the helium partial pressure equals 10^{-8} atm-cc/s. An atmosphere-cc equals 0.76 torr-liter. Solving for pressure gives 7.6×10^{-11} torr.

Next, given a sealed, evacuated 10 liter vacuum system containing an Extorr RGA, how long must you wait before a 10^{-8} atmosphere-cc/s helium leak would produce a 10^{-8} torr peak?

An atmosphere-cc equals 0.76 torr-liter. So if this amount of helium goes into a 10 liter volume, the helium pressure would increase by 7.6×10^{-10} torr every second. It takes about 13 seconds to produce a 10^{-8} torr peak. For this to be useful, the base pressure of the vacuum system must be low enough for RGA operation and must remain low enough

during those 13 seconds without pumping. So a good UHV pump with a gate valve and a system that has either been pumped for many hours, or has been baked, is required.